



Shear Strength

Steel plate shear walls made this hospital expansion possible.

BY ANNE B. MONNIER, P.E. AND ANTHONY P. HARASIMOWICZ, P.E.



RAPID POPULATION GROWTH HAS TRANSFORMED THE CITY OF PORTLAND, ORE. IN THE LAST DECADE.

Area planners predict an influx of another one million residents in the general region over the next 25 years. To meet the city's changing demographics and increased health-care needs, Providence Health System undertook a major expansion of its Providence Portland Medical Center (PPMC) campus.

The overall master plan included a seismic upgrade and expansion of the campus' central utility plant, as well as a newly constructed 900-space parking garage and three-story Child Center addition. But the most significant portion of this endeavor is the new \$126 million North Pavilion Cancer Center, a 486,000-sq.-ft, 11-story building that will significantly increase patient care services and add state-of-the-art research facilities.

Set in the midst of a dense residential area, the site is bordered on one side by a freeway and surrounded by existing facilities on its three remaining sides. In addition to the challenges of the constrained site, the owner wanted direct connections between the North Pavilion, existing hospital wings, and new parking garage. An aggressive program within the limited space also made conventional structural systems problematic. The Portland office of KPFF Consulting Engineers devised creative structural alternatives that not only met PPMC's goals, but also set a new standard for the city.

Assessing the Options

The building site falls in seismic category D in accordance with the 2003 International Building Code (IBC). As an essential facility, the structure is designed to 50 percent higher seismic requirements than ordinary buildings in this somewhat seismically active area.



Above: In locations where the code-prescribed aspect ratio of the steel plate panel was not naturally achieved, KPFF added intermediate horizontal boundary elements (HBEs) with wide-flange steel kickers between floor levels.

Below: Welding details for connecting steel plate shear walls to the boundary elements.

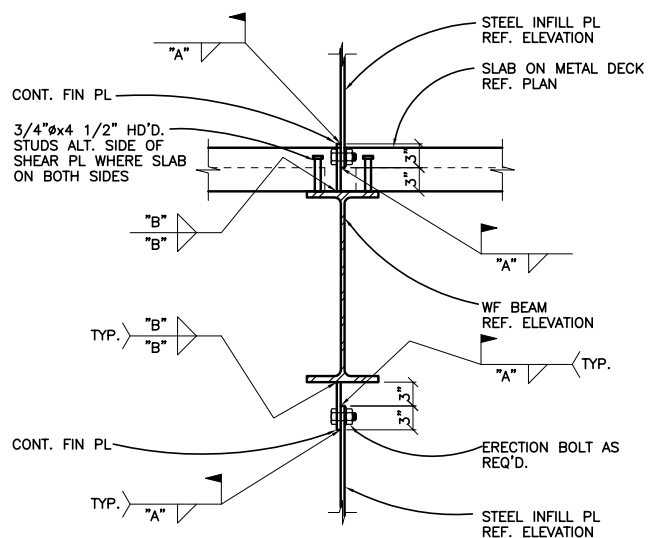

NOTES:

1. DO NOT WELD CONN. BELOW BEAM UNTIL SLAB ABOVE BEAM HAS BEEN POURED.
2. FIN PLATES SHALL BE FROM THE SAME MILL RUN AS THE INFILL PL THEY WELD TO.

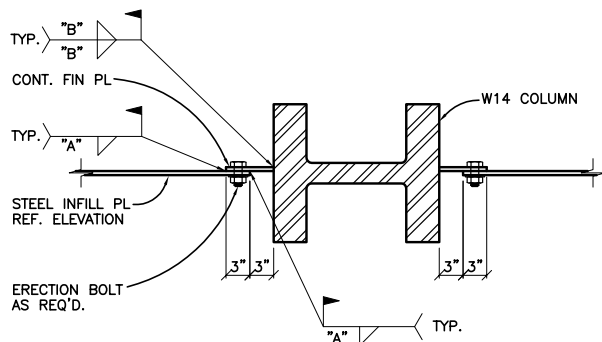

WELDED CONN. OPTION SCHEDULE			
PL THICKNESS	WELD "A" SIZE	WELD "B" SIZE	FIN PLATE SIZE
3/8"	5/16"	5/16"	3/8"
1/2"	7/16"	7/16"	1/2"
1/4"	3/16"	3/16"	1/4"

SPSW DETAIL-WELDED OPTION

By the time the structural engineers became involved, PPMC user groups and representatives had already defined the North Pavilion's building program. The plan included a cancer treatment and research floor, a mechanical level, five patient floors, an outpatient clinic, 21 operating rooms, three linear accelerators, and two MRI units. Engineers originally proposed a lateral system composed of steel-braced frames for cost efficiency, but the number of frames required to resist the substantial seismic lateral loads did not work well with the established program layout.

The second proposed system would have placed concrete shear walls around the elevators and stair shafts, since these areas were consistent vertically throughout the building. While the shear wall system met program requirements, staging the concrete work would have added nearly three months to the project schedule.

A steel moment frame was also considered but, in order to meet seismic requirements, the building required interior moment frames as well as traditional perimeter moment frames. This option proved unfeasible, because the North Pavilion's floor-to-floor heights had to align with those of the existing hospital, and the large amount of mechanical, electrical and plumbing infrastructure above the ceilings did not leave enough space for the deep interior frame beams. Furthermore, city code restrictions prohibited an increase in building height.

Exploring a New Solution

Although there are currently few buildings in the United States with steel plate shear walls (SPSWs), engineers decided that this system was the right fit for PPMC. The advantages were clear. Stronger than braced frames, the system would not require as many walls, there would be no impact to the project schedule, and it would not affect the alignment between the new and existing buildings. In addition, fabrication of SPSWs is simpler, and tests across the globe show that SPSWs are among the best-behaving systems under seismic conditions.

"We're able to produce a high-performance seismic system without terribly sophisticated fabrication requirements," explains Tim Fraser, chief engineer at Cannon Western Constructors, Inc. "And because it's a simpler fabrication, that helps lower costs and shorten the schedule."

Despite its benefits, the SPSW system produced its own challenges. In the spring of 2004, only early draft versions of the new 2005 AISC *Seismic Provisions for Structural Steel Buildings* were available, and the system would technically not be adopted into code until the 2006 IBC. As a completely untested system in the City of Portland, engineers had to demonstrate shear wall behavior in earthquake conditions while meeting the higher code standards for essential facilities. The building stands at 160 ft, the maximum height limit allowed for SPSWs. Engineers had to convince the city's structural advisory board of the system's effectiveness before the city would approve its application.

With limited information available on practical SPSW design and detailing, engineers contacted professors in the United States and Canada to obtain additional design and test data. (Note: AISC *Design Guide 20: Steel Plate Shear Walls* will be available in 2007 and a short course on Steel Plate Shear Walls will be offered at the 2007 NASCC: The Steel Conference.) They built a large ETABS computer model of the SPSW system, including the plates as well as the beams and columns bounding the plates—i.e., vertical boundary elements (VBEs) and horizontal boundary elements (HBEs). Each plate panel was broken down into 10 diagonal strips to model plate tension field action.



Shear walls are strategically located around the stair and elevator shafts and at solid exterior walls in order to avoid penetrations from doors and windows.

Designing for Strength

Large holes in the steel plates would compromise the system, composed of short wall segments, so doors and mechanical ductwork could not penetrate the walls. KPFF worked closely with the project architect, Zimmer Gunsul Frasca Partnership, to strategically place the plates at designated locations within the building, around the stair and elevator shafts, and at windowless perimeter areas.

The theory behind the behavior of SPSWs in a seismic event is that the plate (web element) will experience large inelastic deformations, while the VBEs and HBEs must remain elastic. This also needs to be the case under forces generated by fully yielded webs. Thus the actual-versus-theoretical plate yield strength becomes extremely important in the design of the system. Recent studies have shown that the ratio of expected yield stress to specified minimum yield stress, R_y , for ASTM A36 plate material is 1.3 rather than 1.1, as specified in previous codes. These new findings significantly increase design loads on the system's VBEs, anchors bolts, and foundations.

Engineers contemplated making the $\frac{1}{4}$ - to $\frac{1}{2}$ -in.-thick plates as thin as $\frac{1}{8}$ in. to help decrease the required strength of the rest of the system and save on project expenses. This idea was impractical from a construction standpoint, as concerns arose over such thin plates bending while being maneuvered in the field. Another potential problem was heat distortion from welding plates thinner than $\frac{1}{4}$ in. Engineers also investigated possible options using lower plate grades, as well as limiting the expected-to-specified yield stress ratio of A36 plates. However, neither of these options proved viable given the plate material available.

HBE-to-VBE joint connections following FEMA 350's prequalified WUF-W configuration for ordinary and special moment frames proved a cost-effective option. Additionally, the use of continuity plates was limited due to the stout VBE columns as large as W14x730.

With the research level's 18-ft floor-to-floor heights, the code-prescribed aspect ratio of the steel plate panel was not naturally achieved. KPFF resolved this discrepancy by adding intermediate HBEs with wide-flange steel kickers between floor levels. Beam and kicker placement became a coordinated effort with the MEP engineers to prevent interference with the mechanical, electrical, and plumbing systems.

Erecting the System

Meticulous pre-planning made the erection process go smoothly. With an aggressive construction schedule, nearly 7,500 shop drawings for the 5,600-ton building were reviewed in just over 18 weeks.

Turner Construction Company worked with all the disciplines during pre-construction to mitigate the complexity of aligning the panel plates, and spoke with other contractors who had worked on previous SPSW installations.

"Once the plates were aligned and temporarily hung, the system went up quickly. It's a truly viable shear wall solution and we would recommend the system to any contractor," says Turner's project executive, Jerry Grogan.

Lifting the unusually large columns into place on a site surrounded by existing buildings posed challenges as well. Turner chose the best position for the tower crane based on column weight data, but a mobile crane was still required to place some of the heavy lower-level columns. The team carefully coordinated and detailed the location of column splices to reduce crane pick weights.

To support the lateral system, engineers designed large mat footings between 6- and 8-ft-deep. In order to develop the large tension forces due to overturning as well as SPSW strength requirements, ASTM A354 Gr. BD anchor rods were specified with diameters up to 4 in. and embedments as long as 84 in.

The design team provided options for both bolting and welding the steel infill plates to the beam and column tabs. Bolts would have to be placed every 8 in. on center, which did not leave much room for construction tolerance, considering alignment of all the holes. Ultimately, the welding detail was chosen.

Seismically Stable

The North Pavilion's structural frame is now complete, and the building will welcome patients in early 2008. The new facility will also aid future seismic designs by collecting acceleration data via three accelerographs placed at ground level, mid-height, and the top level of the building. Although Providence Health System's primary concern was to have a facility that functioned well, the installation of this innovative SPSW system provides an added bonus, placing the North Pavilion at the nation's forefront in terms of seismic technology. **MSC**

Anne Monnier is an associate at KPFF Consulting Engineers in Portland, Ore. Anthony Harasimowicz is a project engineer at KPFF.

Owner

Providence Health System, Seattle, Wash.

Architect

Zimmer Gunsul Frasca Partnership, Portland, Ore.

Structural and Civil Engineer

KPFF Consulting Engineers, Portland, Ore.

General Contractor

Turner Construction Company, Portland, Ore.

Steel Fabricator

Canron Western Constructors, Inc., Portland, Ore. (AISC member)

Engineering Software

ETABS, RAM Structural System